

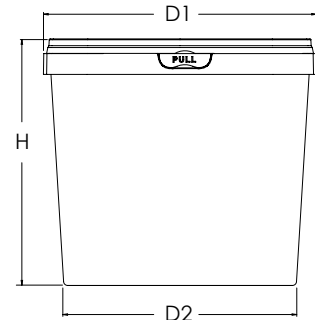

FA10LT
Bucket technical characteristics

Dimensions

D1: 274.37 mm
D2: 221.38 mm
H: 261 mm *without the lid*
Deviation ±1mm



Other elements

Capacity (LT)	Volume to rim 9.700 LT	Brim full volume 11.160 LT
Net weight / Deviation (±2.5%)	300 gr	
Handle	Plastic	Weight 19.5 gr
	Metallic	Weight 43 gr
Buckets packaging	Pallet 1.000 pcsc or 660 pcs	
Decoration	IML Label 765,5X238 mm	Dry Offset 740X195 mm
Packaging	4 Vertically	



Lid technical characteristics

FA10LT

Dimensions

D: 270 mm
H: 13.8 mm
Deviation ±1mm

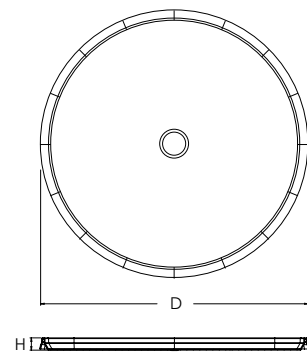

Other elements

Lid weight (gr) Deviation (±2.5%)	77 gr	
Lid packaging	Pallet 2.000 pcs	
Decoration	Dry Offset Ø 156mm	

USEFUL STORAGE INFORMATION: To preserve the quality of this product, it is recommended that it be stored in its original packaging, away from any source of local heat and moisture, away from direct sunlight (below 30°C) and dry conditions. It is recommended that the product be allowed to reach operating temperature 24 hours before use.

RAW MATERIAL: Polypropylene (PP)



ISO 22000/ISO 9001/FSSC 22000

